

REV	DESCRIPTION	ECN #	CHG BY	DATE	APP'D
A	UPDATED ELEMENT SPECS	17839	TAS	12/04/19	NAD

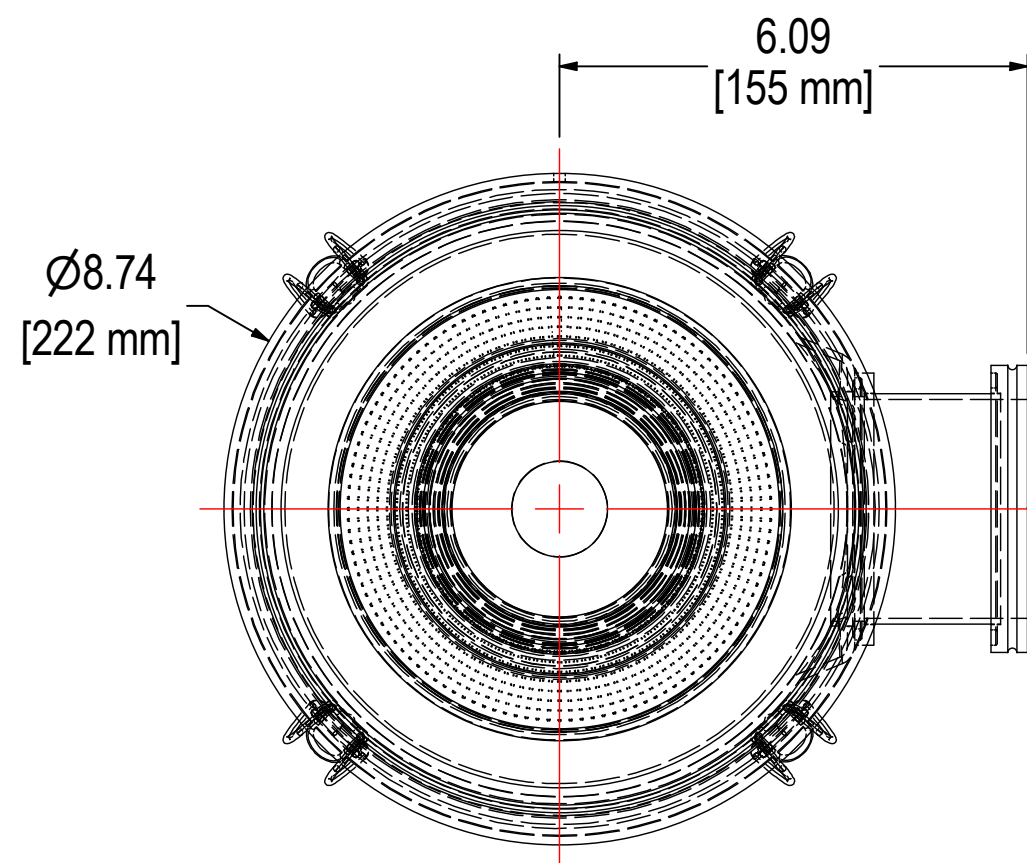

FLANGE FACE SURFACES TO BE FREE OF SCRATCHES, DIVOTS, OR ANY DEFORMATION THAT AFFECTS SEAL. FLANGE FACES TO BE PROTECTED DURING SHIPMENT.

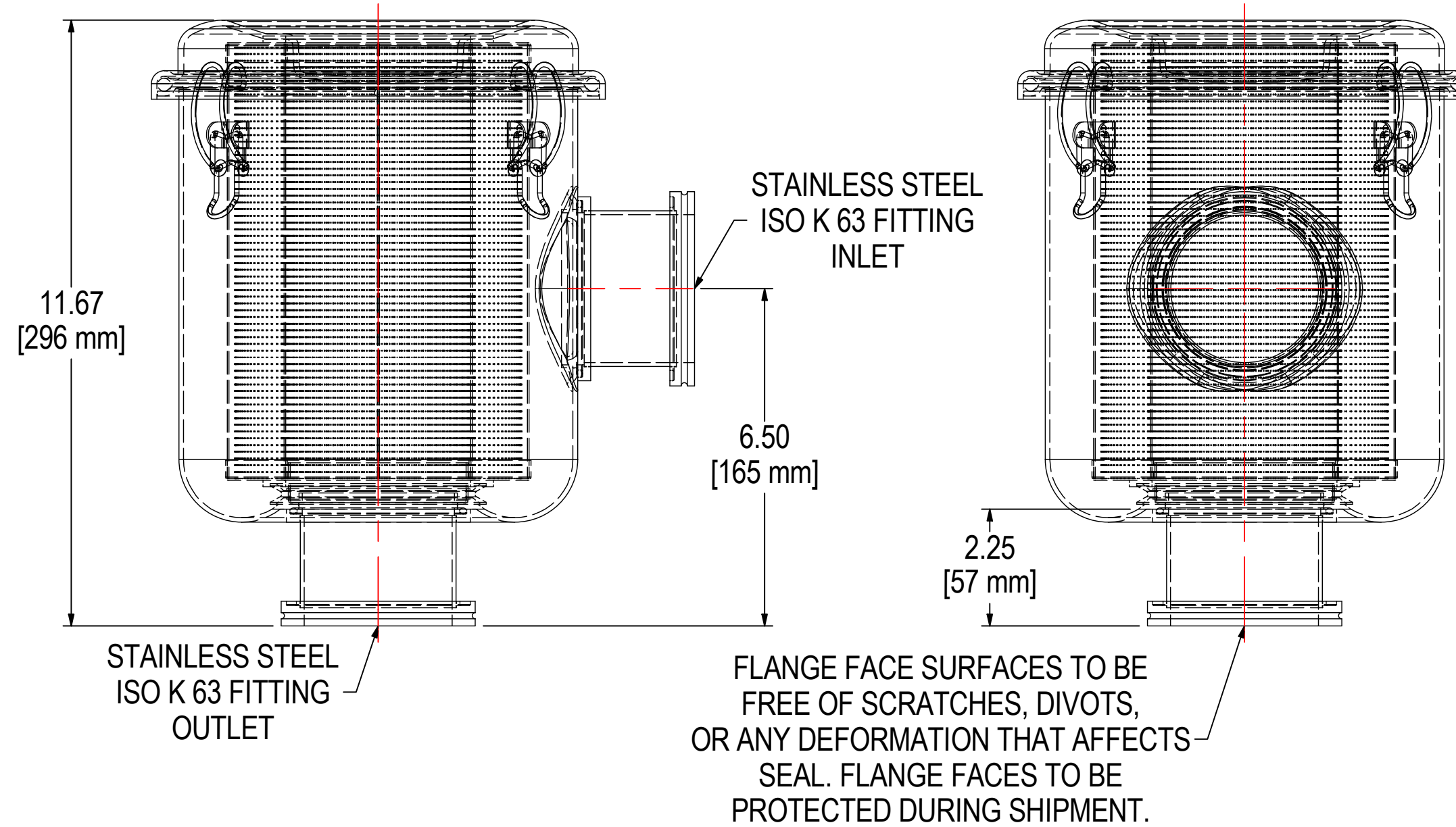

FLANGE FACE SURFACES TO BE FREE OF SCRATCHES, DIVOTS, OR ANY DEFORMATION THAT AFFECTS SEAL. FLANGE FACES TO BE PROTECTED DURING SHIPMENT.

NOTES & SPECIFICATIONS:

1. FLANGES TO BE PROTECTED DURING PRODUCTION & SHIPMENT.
2. UNIT TO BE HELIUM LEAK TESTED TO 1×10^{-5} mbar L/s.

ELEMENT SPECS		
PART NUMBER	850	
MATERIAL	PAPER	
FLOW RATE	290 CFM	493 m ³ /hr
SURFACE AREA	13.1 ft ²	1.2 m ²
I.D.	3.50"	89mm
O.D.	5.88"	149mm
HEIGHT	8.69"	221mm

MODEL #: WL-850-K63B	MATERIAL: CARBON STEEL	FINISH: BLACK POWDER	SHEET: 1 OF 2
MODEL NUMBER: WL-850-K63B		DESCRIPTION: WL-850-K63B, BLACK	
PROJECT:	DRAWN BY: TAS DATE: 7/10/2019	APPROVED BY: EZR DATE: 7/10/2019	REV: A



THE INFORMATION CONTAINED HEREIN IS CONFIDENTIAL AND THE PROPERTY OF SOLBERG MANUFACTURING INC. AND IT IS FURNISHED TO YOU WITH THE EXPRESS UNDERSTANDING THAT IT WILL NOT BE REPRODUCED, COPIED IN ANY MANNER, LOANED OR OTHERWISE TRANSFERRED TO OTHERS ENTIRELY OR IN PART, NOR USED FOR ANY PURPOSE OTHER THAN FOR WHICH IT WAS FURNISHED. IT WILL BE RETURNED UPON REQUEST TO SOLBERG MANUFACTURING INC. THE ABOVE RESTRICTION IS IN ADDITION TO, AND DOES NOT IN ANY WAY ALTER, ANY OTHER RESTRICTIONS WHICH MAY APPLY TO THE INFORMATION CONTAINED HEREIN.

TOLERANCES
DIMENSIONS ARE FOR REFERENCE ONLY. ALL DIMENSIONS ARE SUBJECT TO CHANGE UPON PRODUCTION.
UNLESS OTHERWISE SPECIFIED:
 -DIMENSIONS ARE IN INCHES
 -REF: APPROXIMATE DIMENSIONS, NO TOLERANCES APPLY
 -FINISH: BREAK EDGES TO .005-.020 RADIUS/CHAMFER